



NEW! **DeBurr-Z**
CNC Deburring Tool
with
Compression and Extension Float

- Deburr parts quickly and consistently on the CNC machine eliminating the need for tedious hand work.
- The DeBurr-Z floats in both compression and extension allowing the cutting tool to follow the top edges or underside edges of the work piece, even when these are not clearly defined like in the case of castings and cross holes.
- Adjust the force to increase or decrease the pressure depending on the type of material and desired edge break.

Top Edges



Underside Edges



Intersecting



CNC tool holder for deburring and chamfering

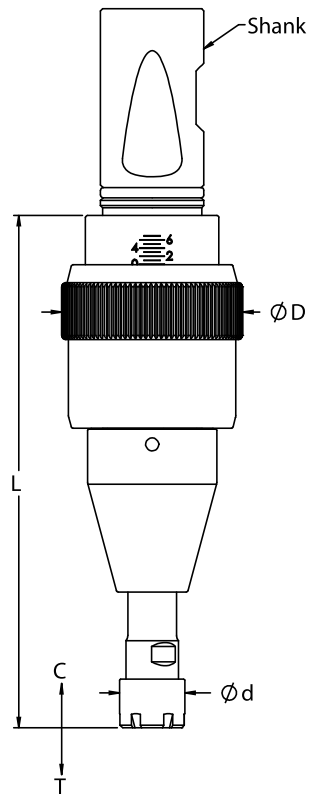

- for deburring, and chamfering on CNC machines.
- floats in compression and extension for deburring the topside or underside edges of the work piece.
- the floating holder allows the cutting tool to follow the edges of the work piece even when these are not clearly defined like in the case of castings or cross holes.
- improves the life of cutting tools thanks to the adjustable compression force.
- speeds up the process by allowing faster approach feed rates.
- the compression and extension force can be simultaneously and equally adjusted for increasing or decreasing the pressure of the cutting tool against the work piece.
- ER11 collet holds a wide variety of burr cutting tools.
- easy programming and installation on the CNC machine.

How to Order

Please select the DeBurr-Z (A) and shank (B) to fit your application. Please order ER11 collets and Burrs separately.

(A) Model	Order code	Shank	Collets (Capacity)	Max. RPM	Compression C	Extension T	d	D	L	Weight kg
DeBurr-Z	57301	1"	ER11 (2.5-6.5)	10,000	10	10	16	44	128	0.7
	57320	20 mm								
	57325	25 mm								

Note: All dimensions are shown in mm. 25.4mm = 1".



The DeBurr-Z can be used with spherical and angular shaped burrs, like the examples shown here, made from HSS or Carbide in a variety of sizes and tooth patterns.

